

Skeleton Grapple



Features

- ❖ Multi-use grapple with an open design to hold what is needed while sifting out the rest.
- ❖ Two-cylinder independent grapple, designed to scrape with loader arms against boom stops.
- ❖ Hauling brush and logs, wider than the attachment, is easy with the open sided design.
- ❖ Replaceable Teflon® coated bushings provide lubrication at all pivot locations.
- ❖ Tines made of 1/2" Grade 80 steel and jaws made from 1/2" Grade 50 steel.
- ❖ Corrosion, dent and flake resistant NitroSteel® cylinder rods made in the USA.
- ❖ Machine specific hydraulic package to completely protect hose routing.

OPTION: Cylinder Guards



Guards protect cylinders from damage.

Skeleton Grapple Specifications

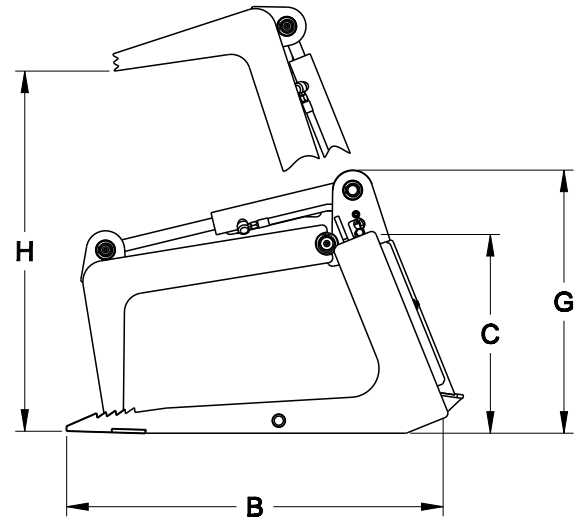
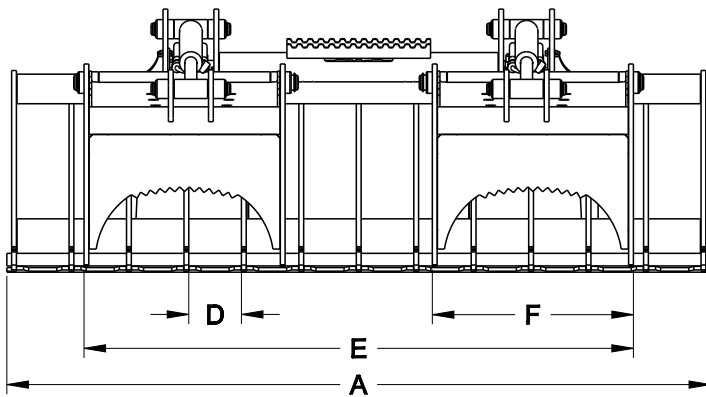

MODEL	SGV60	SGV66	SGV72	SGV78	SGV84	SGV90
(A) Overall Bucket Width (Inches)	61.5	67.5	73.5	79.5	85.5	91.5
(B) Bucket Depth (Inches)	39.9					
(C) Bucket Height (Inches)	21.3					
Number of Tines (With Sides)	11	12	13	14	15	16
(D) Space Between Tines (Inches)	5.5					
Bucket Tine Thickness (Inches)	0.5 ¹					
(E) Overall Grapple Width (Inches)	57.4					
(F) Independent Grapple Width (Inches)	21.0					
(G) Height with Grapple Closed (Inches)	27.5					
(H) Grapple Jaw Opening (Inches)	37.6					
Approximate Weight (Pounds)	815	850	885	920	955	990
Recommended Loader Capacity (Pounds)	Greater than 1500					

¹ Tine Material is Grade 80 Plate (80,000 PSI Minimum Yield Strength).

Additional Info

- 1 9/16" diameter hinge pins.
- 2" bore, 8 3/8" stroke cylinders with 1 1/4" NitroSteel® cylinder rods and 1 1/4" cylinder pins.
- Hoses from grapple to loader and couplers included.

Specifications and designs are subject to change without notice.



Virnig Manufacturing Inc.
 800-648-2408
 attachments@virnigmfg.com
 www.virnigmfg.com